

STEAM HUMIDIFIER

The most preferred method of home humidification.



EVC®
CONTROLS, INC.

autoFlo®
Whole House Humidifiers

The World's Most Efficient Humidifier Just Got Better!

- Computer watchdog circuit
- Automatic Drain/Flush system
- Highest efficiency rating
- Automatic maintenance mode
- 100% guaranteed no summer maintenance
- Interlocking wiring for fan control

- Humidifies without a call for heat
- LED's for system readout
- Most effective cure for dry homes
- Listed and Approved by UL
- Compatible with all forced air systems

The most technologically advanced humidifier has become better with the help of a computer. The S2000 and S2020 Steam Humidifiers have a built-in computer chip to insure efficiency, accuracy, reliability and safety.

The automatic flush system will drain the humidifier every (12) twelve hours of operation. This is a preventative maintenance mode to help insure maximum unit efficiency. The humidifier will completely empty itself and not refill until another call for humidity. This mode insures that all summer long, when the humidifier is not in operation the unit will not be full of water.

The LED read-out display on the front cover shows the proper operation of the unit. The display also shows the installer and homeowner the effectiveness and the reliability of the unit.

The only humidifier that will operate in the heating system without a need for a heat call. The steam humidifier, model S2000 and S2020 will operate and turn the fan on independently of the furnace. The ultimate operation for maximum homeowner comfort.

The UL label enforces EWC's commitment to product reliability and safety. Underwriters Laboratories (UL) is an independent auditing agency that rigorously tests the performance of electrical devices. Their seal is a symbol of excellence.

The S2000 and S2020 are compatible with all makes and models of forced air heating units. The steam humidifier is the only humidifier that will work to its maximum capacity on heat pump systems.

Specifications

S2000		S2020	
Output Capacity	16 gal/day	Output Capacity	22 gal/day
Square Footage	2,800 sq. ft.	Square Footage	3,500 sq. ft.
Voltage	120	Voltage	220 VAC
Electrical	1.4 KW, 15 amps	Electrical	2.0 KW, 10 amps
Plenum Opening	6" x 6"	Plenum Opening	6" x 6"
Weight	9 lbs.	Weight	9 lbs.
Humidistat included		Humidistat included	

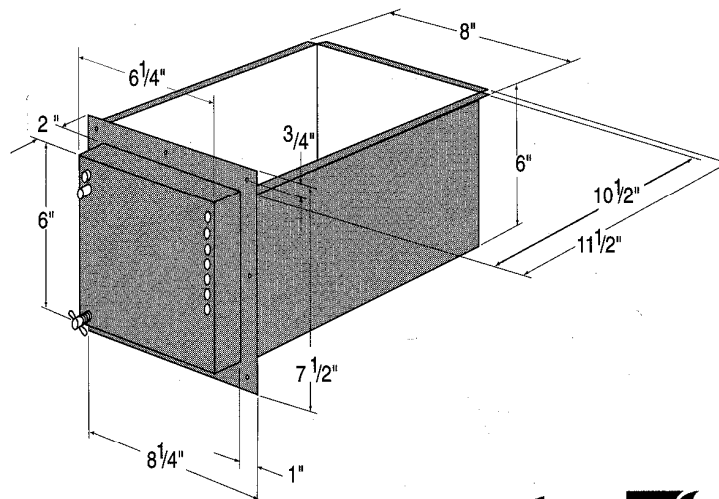

EWC[®]

autoflo[®]

385 HIGHWAY #33 ENGLISHTOWN, NJ 07726

Telephone: 800-446-3110 • Fax: 800-635-8646 • www.ewccontrols.com